

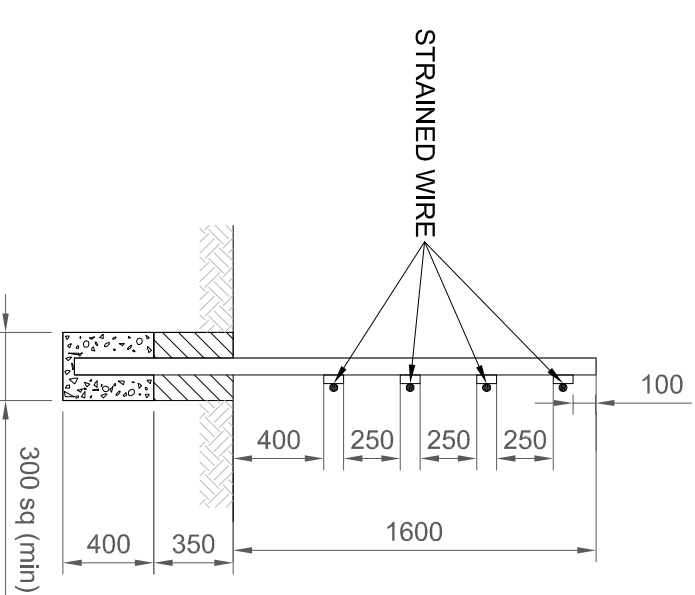



TIMBER POST AND 4 RAIL WITH WIRE FENCE TYPE F5



SECTION THROUGH CENTERLINE OF MAIN POSTS

NOTES

1. All dimensions are in millimetres.
2. All posts and struts to be sawn timber.
3. 4 rail fence - BS 1722 part 7 applies unless otherwise stated.
4. Details of posts and connections shall be in accordance with Drawing Nos. M8MF JV/AW/003 F3 and 004 F4.
5. The wire shall be fixed on the field side of the fence unless otherwise stated.
6. Posts can be supported by rammed backfill or concrete ST2 as required.
7. Where plain or barbed wire is required it shall be comply with BS EN 10223-4.

CLIENT	PROJECT TITLE		DRAWING TITLE	
 The Scottish Government	M8 M73 M74 Motorway Improvements		Accommodation Works Timber Post and Rail with Wire Type F5	
	REV	REVISIONS	BY	CHKD / APPD
AMENDMENTS		DATE	DATE	DATE
<small>This map is based upon Ordnance Survey material with the permission of Ordnance Survey on behalf of the Controller of the Majesty's Stationery Office (Crown Copyright). Any use of this map, or any part thereof, in any form, or by any means, without the prior written permission of the Controller of the Majesty's Stationery Office is prohibited.</small>				
DESIGN BY:	DM	CHECKED BY:	MLB	
DATE:	JAN 10	DATE:	JAN 10	
DRAWN BY:	DM	APPROVED BY:	WW	
DATE:	JAN 10	DATE:	JAN 10	
DRAWING STATUS	CONTRACT			
ENGINEER		 IN ASSOCIATION WITH 		
SCALE @ A3	DRAWING NO	REV		
MNS	M8MFJV/AW/005	—		